



夹持输送案例



夹持输送案例



阻滑输送案例



阻滑输送案例

Contents (目录)	2	Examples of application (应用场合)	19
Chains (链条)	5		
Conveyor beam (输送梁)	5		
End drive units (驱动单元)	8		
Idler units (从动单元)	10		
Horizontal wheel bends (水平轮弯头)	11		
Horizontal plain bends (水平弯头)	14		
Vertical bends (垂直弯头)	16		



CX85

Chain width 83 mm (链宽83mm)



Technical characteristics (技术指标)

Chain tension limit (链条张力极限)1250 N
Beam width (型材宽度)85 mm
Chain width (链条宽度)83 mm
Chain pitch (链条节距)33.5 mm
Item width (输送物品宽度)20-200 mm
Maximum item weight (输送物品重量)	
Horizontal transport (水平传送)15 kg
Vertical transport (垂直传送)10 kg
Maximum weight on conveyor (线体最大承载)200 kg
Maximum conveyor length (线体最大长度)30 m
Vertical wedge conveyor applications (夹持应用场合)	
Item width (输送物品宽度)40-300 mm
Maximum: conveyor length (输送物品长度)8 m
item weight (输送物品重量)2 kg

Examples of application

Ball valves, water meters, disk drives, pie packages, plastic bottles, beverage cans, products on pallets, paint cans, socks.

应用场合

球阀、轴承、电机转子、汽车零部件、塑料瓶、易拉罐、低压开关、仪器仪表、纸巾、包装食品、工装托盘等。

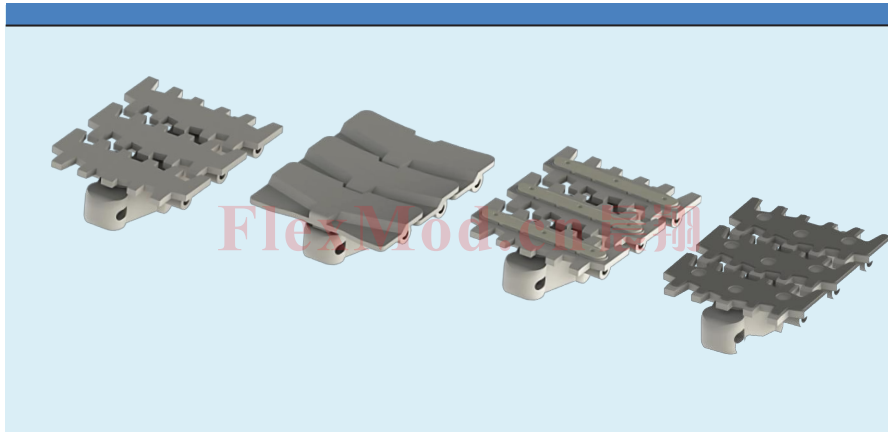

Plastic chain materials(链板材质)	Performance(特性)	Colour(颜色)
POM	Standard material/标准材料	white/白色
POML	Ultra low wear/超润滑	white/白色
POMA	Abrasion resistance/超耐磨	white/白色
POMC	Chemical resistance/抗腐蚀	yellow/黄色
POME	Conductive material/抗静电	black/黑色
POMK	High temperature resistance/耐高温	yellow/黄色
POMF	Food application/用于食品	white/白色
POMN	Low noise/低噪音	white/白色

Plain chain (平板链)

CXBTP 5A85 Plain chain
Length 5 mt
(平板链, 长度5m)

CX5059652 Plain link
(平板链节)

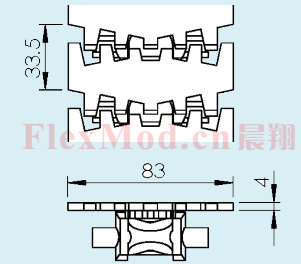

CXBTP 5A85 A Closed top chain
Length 5 mt
(封闭式顶链, 长度5m)

CX5059685 Closed top link
(封闭式顶链节)

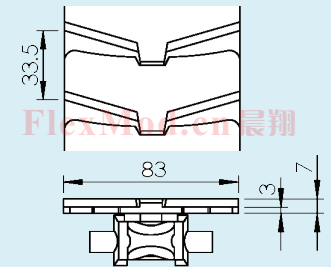

CXBTP 5A85 F Friction top chain
(防滑顶链)

CX5110459 Friction top link
(防滑顶链节)

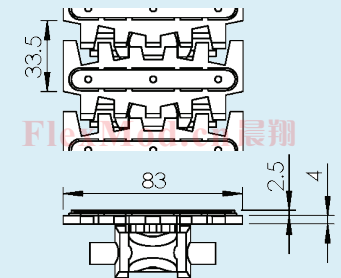

CXBTP 5A85 TF Steel top chain (钢顶链)

CX5110436 Steel top link (钢顶链节)

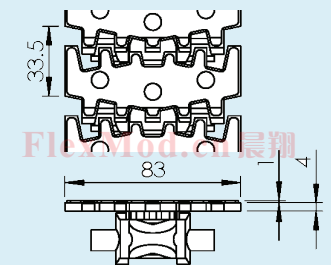

Chains (链条)

FlexMod®

Tools and accessories (工具和附件)

CXBTT 13X16	Plastic pivot (塑料珠)
CXMTD 6X50	Steel pin (钢销)
CXBMJ 6P	Pin insertion tool (销子安装工具)
CXMMJ 6	Pin insertion tool (销子安装工具)



CX85-4

Conveyor beam (输送梁)

FlexMod®

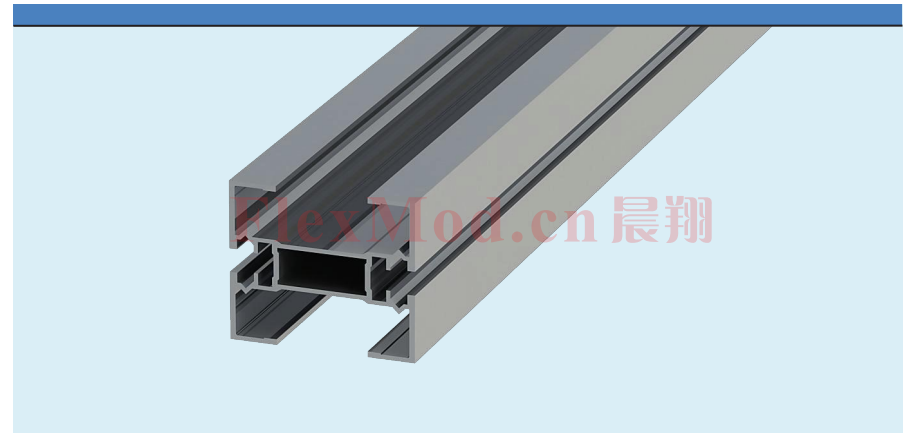

www.flexmod.cn

CX85-5

CX85

Conveyor beam (输送梁)

FlexMod®

CXBCEB 3A85 Length 3 mt (长度3m)

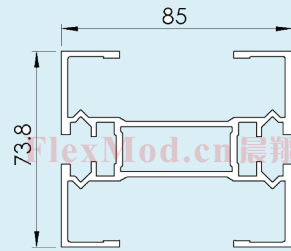

Slide rail (耐磨条)
CXBCR 25 Length 25 m(长度25m)
HDPE White(尼龙)

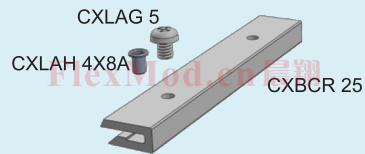

CXLAH 4X8A Aluminium rivet (铝铆钉)

CXLAG 5 Plastic screw (塑料铆钉)

Connecting strip with set screws
(梁体连接条)

CXSCJ 6X160 H=20 mm
Length 160 mm

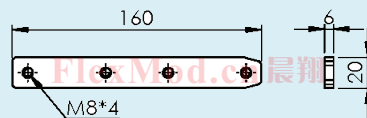

T-slot cover (防尘胶条)

CXCAC 2 Aluminium Length
2 mt

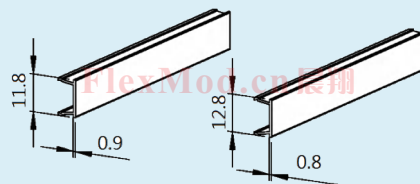

CXCAC 3P Polyvinyl chloride
Length 3 mt

CX3920500 Drill fixture for slide
rail (耐磨条安装工具)

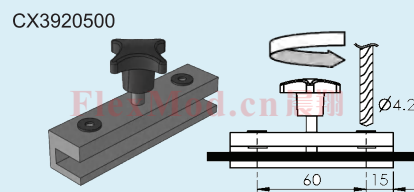

CX85-6

Conveyor beam (输送梁)

FlexMod®

Half beam (半梁)

CXBCEB 3A85H Length 3 m(长度3m)

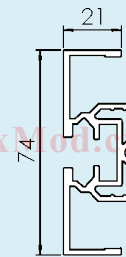

Beam clip (梁夹)

CXBCE 42X20

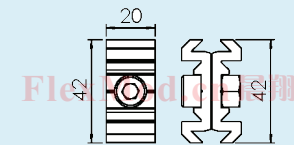

Split Conveyor beam assembled
(组合式输送梁)

Length 3mt (长度3m)

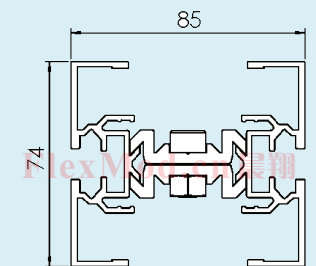

CX85

Beam spacer (型材隔条)

CXLCD 3 Aluminium, anodized
(阳极处理)
Length 3mt (长度3m)

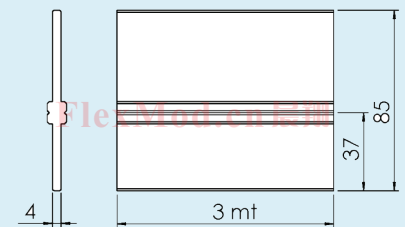

CXS	H=16.0mm
CXL	H=15.9mm
CXM/CX85/CXH	H=10.5mm
CXK	H=0.5mm

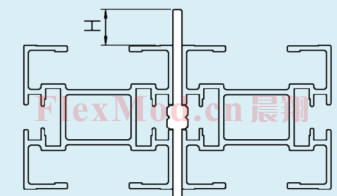

www.flexmod.cn

CX85-7

End drive units (驱动单元)

FlexMod®



CX85-8

End drive units (驱动单元)

FlexMod®

CXBEB 0A85HL Drive unit (驱动单元)
Transmission on left-hand side
(传动装置在左侧)

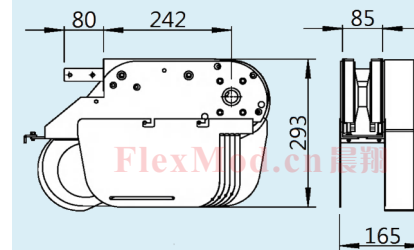

CXBEB 0A85HR Drive unit (驱动单元)
Transmission on right-hand side
(传动装置在右侧)

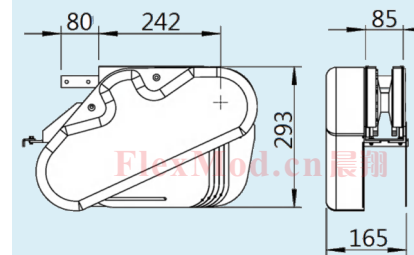

CXBEB 0A85HLP Drive unit (驱动单元)
Direct drive (直接单元)
left-hand side (左出轴)

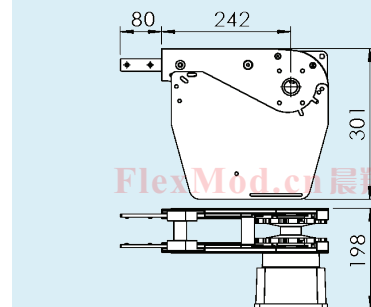

CXBEB 0A85HRP Drive unit (驱动单元)
Direct drive (直接单元)
right-hand side (右出轴)

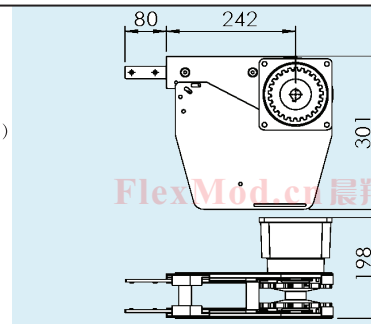

CX85

www.flexmod.cn

CX85-9

Idler end units (从动单元)

FlexMod®



CXBEJ A85 Idler end unit (从动单元)

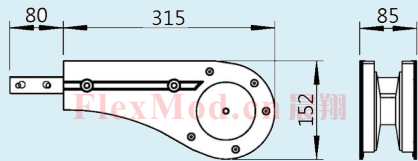

CXMSJ 189 Protective cover for idler end unit (尾端防护罩)

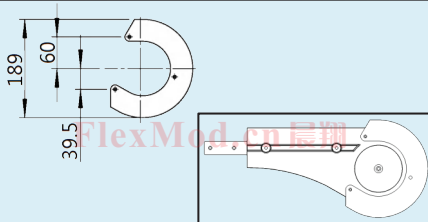

Horizontal wheel bends (水平轮弯头)

FlexMod®



Horizontal wheel bends (水平轮弯头)

FlexMod®

Horizontal wheel bend, 30° (水平轮弯头30°)

CXBBH 30A85R160 Radius to centre of chain 160 mm (链条中心半径160mm)

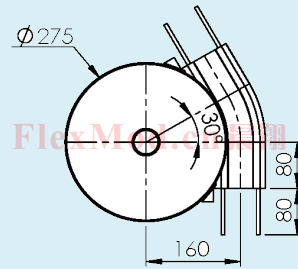

Horizontal wheel bend, 45° (水平轮弯头45°)

CXBBH 45A85R160 Radius to centre of chain 160 mm (链条中心半径160mm)

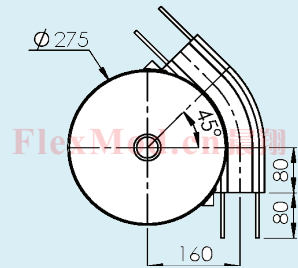

Horizontal wheel bend, 60° (水平轮弯头60°)

CXBBH 90A85R160 Radius to centre of chain 160 mm (链条中心半径160mm)

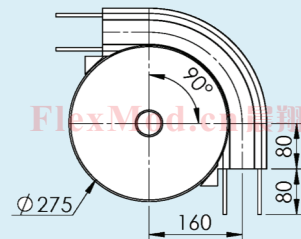

Horizontal wheel bend, 90° (水平轮弯头90°)

CXBBH 180A85R160 Radius to centre of chain 160 mm (链条中心半径160mm)

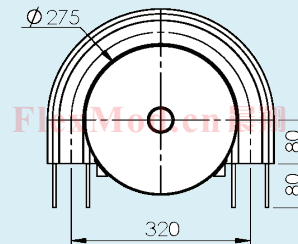

Horizontal wheel bends (水平轮弯头)

FlexMod®

Horizontal wheel bend, 120° (水平轮弯头120°)

CXBBH 210A85R160 Radius to centre of chain 160 mm (链条中心半径160mm)

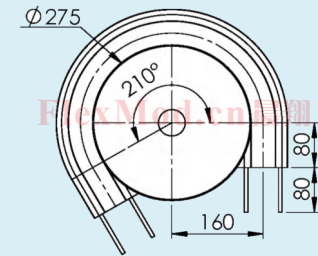

Horizontal plain bends (水平弯头)

FlexMod®

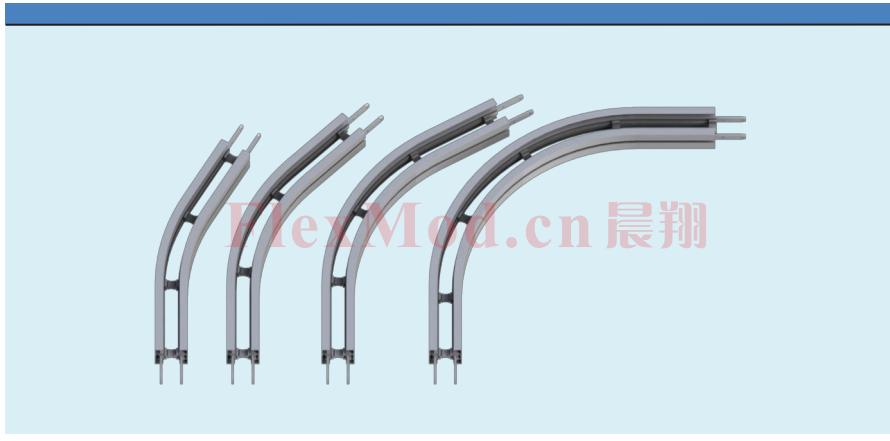

CX85-14

Horizontal plain bends (水平弯头)

FlexMod®

Horizontal plain bend, 30° (水平弯头30°)

Radius to centre of beam:
(输送梁中心半径)

CXBBP 30A85R500	R=500 mm
CXBBP 30A85R700	R=700 mm
CXBBP 30A85R1000	R=1000mm

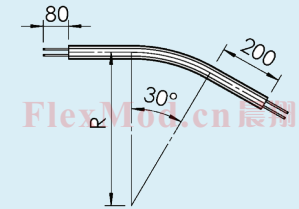

Horizontal plain bend, 45° (水平弯头45°)

Radius to centre of beam:
(输送梁中心半径)

CXBBP 45A85R500	R=500 mm
CXBBP 45A85R700	R=700 mm
CXBBP 45A85R1000	R=1000mm

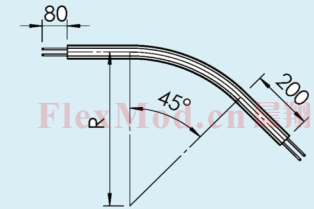

Horizontal plain bend, 60° (水平弯头60°)

Radius to centre of beam:
(输送梁中心半径)

CXBBP 60A85R500	R=500 mm
CXBBP 60A85R700	R=700 mm
CXBBP 60A85R1000	R=1000mm

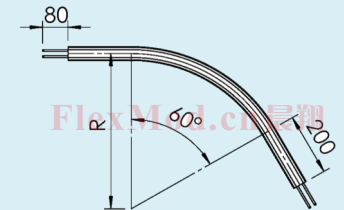

Horizontal plain bend, 90° (水平弯头90°)

Radius to centre of beam:
(输送梁中心半径)

CXBBP 90A85R500	R=500 mm
CXBBP 90A85R700	R=700 mm
CXBBP 90A85R1000	R=1000mm

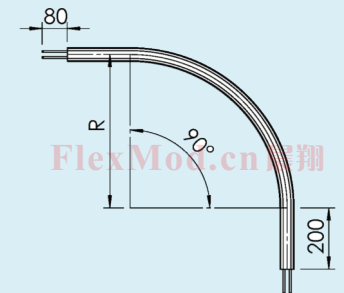

www.flexmod.cn

CX85-15

CX85

Vertical bends (垂直弯头)

FlexMod®

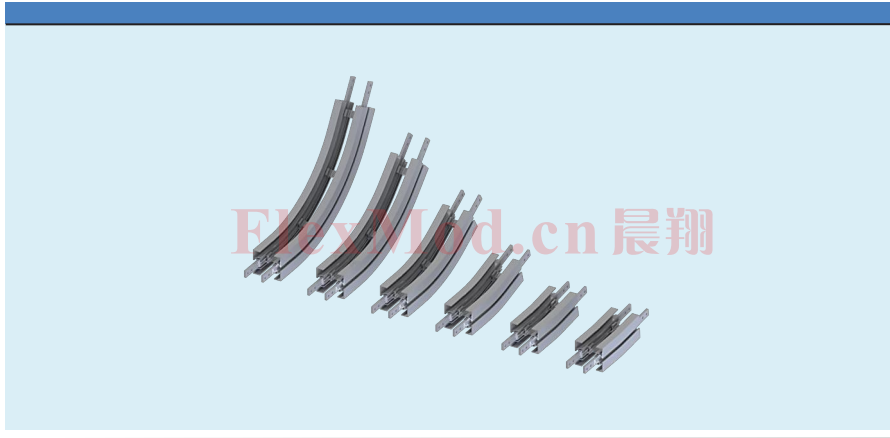

Vertical bends (垂直弯头)

FlexMod®

Vertical bend, 5° (垂直弯头5°)

Radius to centre of beam:
(输送梁中心半径)

CXBBV 5A85R400 R=400 mm

	R	A	B
CXBBV 5A85R400	400	195	9

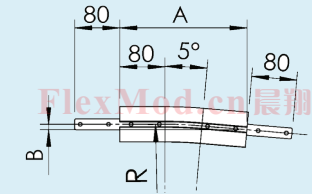

Vertical bend, 7° (垂直弯头7°)

Radius to centre of beam:
(输送梁中心半径)

CXBBV 7A85R400 R=400 mm

	R	A	B
CXBBV 7A85R400	400	208	13

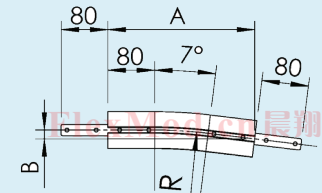

Vertical bend, 15° (垂直弯头15°)

Radius to centre of beam:
(输送梁中心半径)

CXBBV 15A85R400 R=400 mm

CXBBV 15A85R700 R=700 mm

	R	A	B
CXBBV 15A85R400	400	261	34
CXBBV 15A85R700	700	338	45

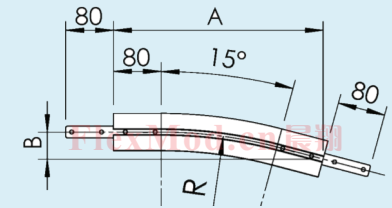

Vertical bend, 30° (垂直弯头30°)

Radius to centre of beam:
(输送梁中心半径)

CXBBV 30A85R400 R=400 mm

CXBBV 30A85R700 R=700 mm

	R	A	B
CXBBV 30A85R400	400	349	94
CXBBV 30A85R700	700	449	134

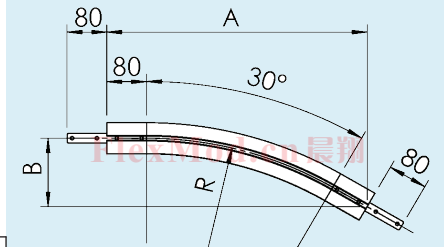

CX85

Vertical bends (垂直弯头)

FlexMod®

Vertical bend, 45° (垂直弯头45°)

Radius to centre of beam:
(输送梁中心半径)

CXBBV 45A85R400 R=400 mm
CXBBV 45A85R1000 R=1000 mm

	R	A	B
CXBBV 45A85R400	400	419	174
CXBBV 45A85R1000	1000	844	350

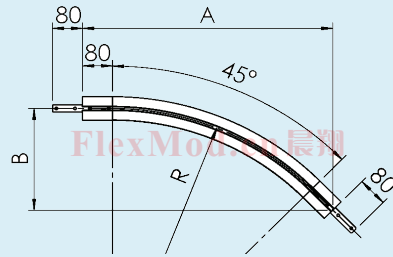

Vertical bend, 60° (垂直弯头60°)

Radius to centre of beam:
(输送梁中心半径)

CXBBV 60A85R400 R=400 mm
CXBBV 60A85R1000 R=1000 mm

	R	A	B
CXBBV 60A85R400	400	466	269
CXBBV 60A85R1000	1000	986	569

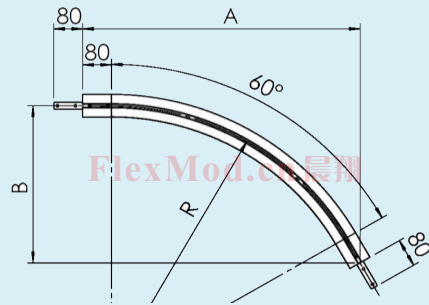

Vertical bend, 90° (垂直弯头90°)

Radius to centre of beam:
(输送梁中心半径)

CXBBV 90A85R400 R=400 mm
CXBBV 90A85R1000 R=1000 mm

	R	A	B
CXBBV 90A85R400	400	480	480
CXBBV 90A85R1000	1000	1080	1080

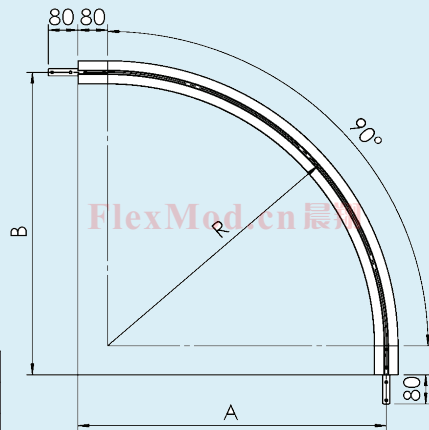

Examples of application (应用场合)

FlexMod®



电气行业输送案例

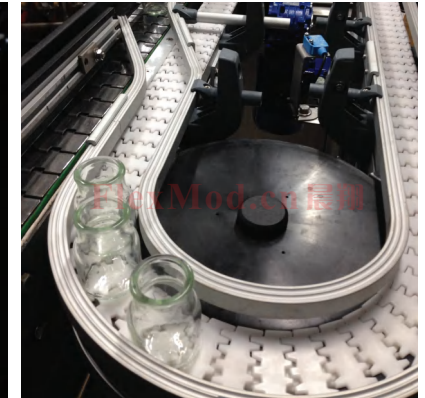

玻璃瓶输送案例

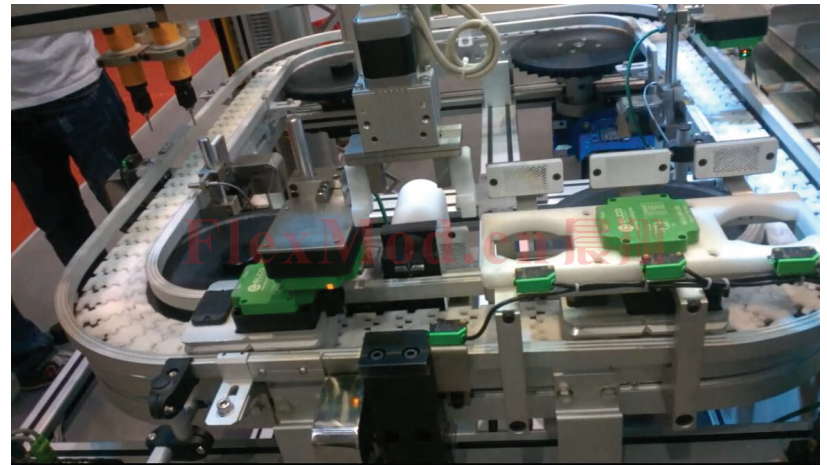

自动组装输送案例

CX85